

Integrated USB TYPE-C Power Bank System-On-Chip with 3A charger, 3.1A discharger

1. Features

- **Switch buck charger and boost**
 - ✧ 3A Synchronous switching charger and 5V 3.1A boost converter
 - ✧ Boost converter efficiency up to 93%
 - ✧ Switching charger efficiency up to 92%
 - ✧ Integrated power-path management, charging batteries and charging cellphones at the same time
- **Charger**
 - ✧ Adaptive charging current control, excellent adapter compatibility
 - ✧ Support TYPE-C port with 3A current, and MICRO-B port with 2A current
 - ✧ Support BC1.2 protocol, compatible with PC USB charge
 - ✧ Support 4.20V/4.35V/4.40V battery
 - ✧ Support battery thermal protection (with NTC resistor)
- **State of charge (SOC) indicator**
 - ✧ Integrated LED controller supports 4/3/2/1 LEDs as the SOC indicator
 - ✧ Configurable charging/discharging curve makes the SOC indicate LEDs more even
- **Fully featured**
 - ✧ Integrated cellphone plug-in and plug-out detector
 - ✧ Integrated TYPE_C DRP protocol, Support for charging and discharging in the one TYPE-C port
 - ✧ support current load compensation
 - ✧ Integrated two DCP modules for detect cellphone charging current
- **Low power**
 - ✧ Smart load detector, switching to standby mode automatically
- **Ultra simplified BOM**
 - ✧ Integrated power FET, charging/boosting with a single inductor
 - ✧ 500kHz switching frequency, supports 1uH inductor
- **Multiple protections, high reliability**
 - ✧ Output over-current, over-voltage, short-circuit protection
 - ✧ Input over-voltage, over-current, battery

over-charge, over-drain, over-current protection

- ✧ Thermal regulation and thermal shutdown, battery NTC protection
- ✧ ESD 4KV, maximum 11V transit over-voltage sustainable

- **Fully customizable**

- ✧ I2C interface makes customization flexible and low-cost

2. Applications

- Power bank, Portable Charger
- Mobile Phones, Smart Phones, Handheld Devices, Portable Media Player, Tablet

3. Description

IP5310 is a fully-integrated multi-function power management SoC. It integrates a boost converter, a Li battery charger management system, a battery state of charge indicate controller, and built-in TYPE-C protocol. It provides a turn-key solution for power bank and portable charger applications.

IP5310's high integration and multiple features make the minimized component number in application. It can effectively downsize the application and lower the BOM cost.

IP5310's synchronous boost converter provides 3.1A output current. Its efficiency is up to 93%. It can switch to standby mode at empty load automatically.

IP5310's synchronous switching charger provides 3A charging current. Its efficiency is up to 92%. It regulates the charging current by IC temperature and input voltage.

IP5310 Support I2C interface .It can customize battery's SOC curve, and indicate the SOC accurately. IP5310 support the SOC indicator of 4/3/2/1 LEDs and flashlight function.

IP5310 is available in QFN32-5*5mm

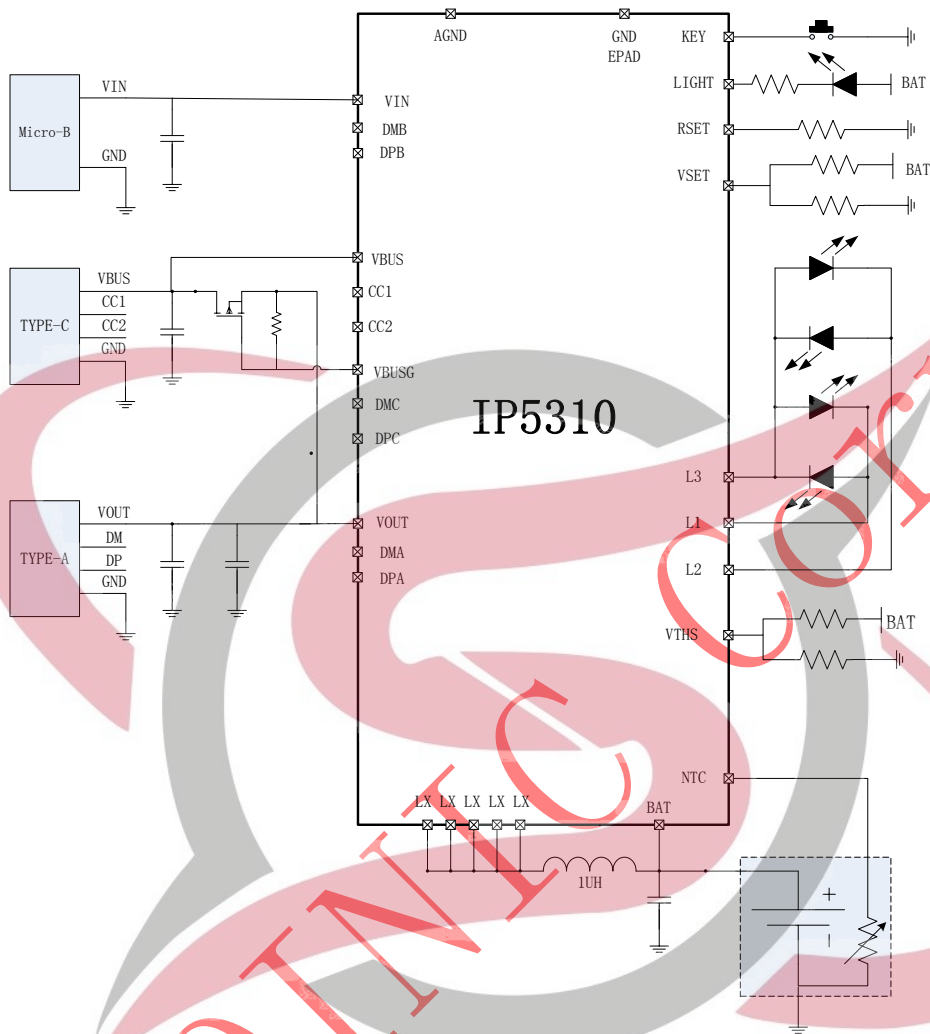

Fig 1 Simplified application schematic (4 LEDs as the SOC indicator)



4. Pin definition

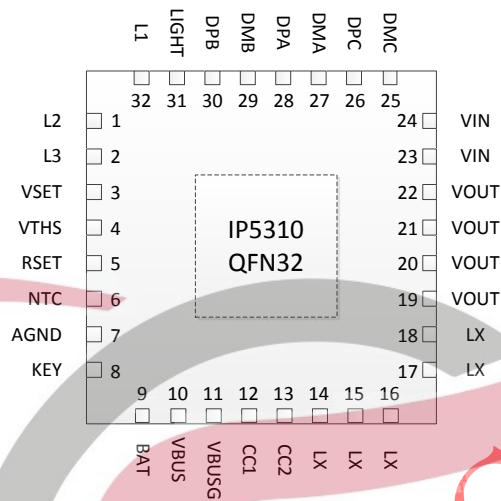

Fig 2 IP5310 Pin Diagram

PinNum	PinName	Descriptions
1	L2/SDA	Battery indicator pin2,SDA when use I2C
2	L3/IRQ	Battery indicator pin3,wake up MCU when use I2C
3	VSET	Battery voltage select(4.20V/4.35V/4.40V)
4	VTHS	Battery OCV select
5	RSET	Battery resistance compensate select
6	NTC	NTC resistor input to sense battery temperature
7	AGND	Analog GND
8	KEY	Key input pin
9	BAT	Battery connection point to the positive terminal of the battery pack
10	VBUS	VBUS PIN for Charge input
11	VBUSG	Gate Drive Pin for Charge input PMOS from VBUS
12	CC1	TYPE-C CC1
13	CC2	TYPE-C CC2
14~18	LX	DCDC switch node, connect to output inductor
19~22	VOUT	DCDC 5V OUTPUT pin
23~24	VIN	Charger 5V input pin
25	DMC	Output USB DCP D1-
26	DPC	Output USB DCP D1+
27	DMA	Output USB DCP D0-
28	DPA	Output USB DCP D0+
29	DMB	Float

30	DPB	Float
31	LIGHT	Output for Torch-Light Driver, Open drain
32	L1/SCK	Battery indicator pin1,SCK when use I2C
33	EPAD	Exposed pad beneath the IC for GND connection and heat dissipation. Always solder to the board, and connecting to ground plane

5. block diagram

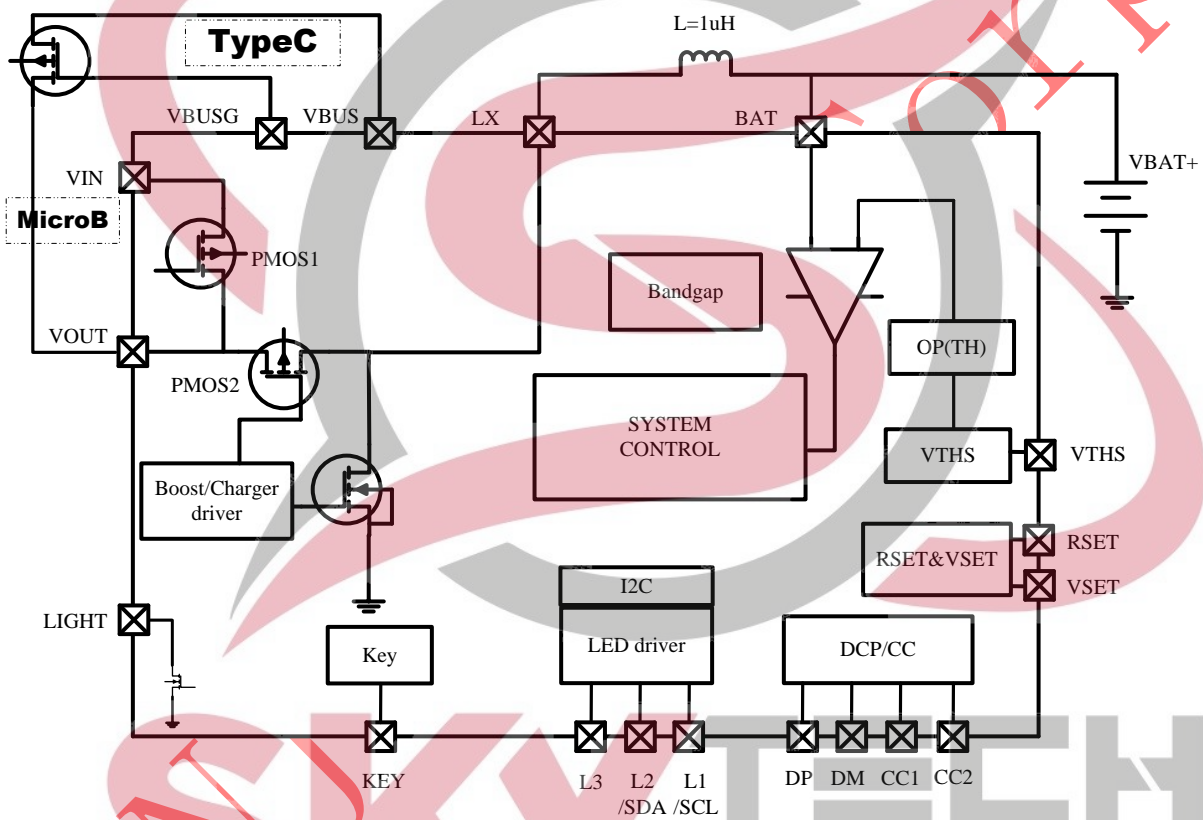

Fig 3 IP5310 block diagram

6. The Part List of Power Bank SoC

PartNum	charger	Boost	LEDs	Torch	KEY	I2C	DCP	Type-C	Quick Charge	Package	
IP5303	1.0A	1.2A	1,2	✓	✓	-	-	-	-	eSOP8	PIN2PIN
IP5305	1.0A	1.2A	1,2,3,4	✓	✓	-	-	-	-	eSOP8	
IP5306	2.4A	2.1A	1,2,3,4	✓	✓	-	-	-	-	eSOP8	
IP5206	2A(Max)	1.5A	3,4,5	✓	✓	-	-	-	-	eSOP16	PIN2PIN
IP5108E	2.0A	1.0A	3,4,5	✓	✓	-	-	-	-	eSOP16	
IP5108	2.0A	2.0A	3,4,5	✓	✓	✓	-	-	-	eSOP16	
IP5207T	1.2A	1.2A	1,2,3,4	✓	✓	-	✓	-	-	QFN24	
IP5189T	2.1A	2.1A	1,2,3,4	✓	✓	✓	✓	-	-	QFN24	
IP5207	1.2A	1.2A	3,4,5	✓	✓	-	-	-	-	QFN24	PIN2PIN
IP5109	2.1A	2.1A	3,4,5	✓	✓	✓	-	-	-	QFN24	
IP5209	2.4A	2.1A	3,4,5	✓	✓	✓	✓	-	-	QFN24	
IP5219	2.4A	2.1A	1,2,3,4	✓	✓	✓	-	✓	-	QFN24	
IP5310	3.1A	3.1A	1,2,3,4	✓	✓	✓	✓	✓	-	QFN32	
IP5312	15W	4A	2,3,4,5	✓	✓	✓	✓	-	✓	QFN32	
IP5318Q	18W	4.8A	2,3,4,5	✓	✓	✓	✓	-	✓	QFN40	PIN2PIN
IP5318	18W	4.8A	2,3,4,5	✓	✓	✓	✓	✓	✓	QFN40	

7. Absolute maximum ratings

Parameter	symbol	value	Unit
Port input voltage range	V_{IN}	-0.3 ~ 6	V
Junction temperature	T_J	-40 ~ 150	°C
Storage temperature	T_{stg}	-60 ~ 150	°C
Thermal resistance (from junction to ambient air)	θ_{JA}	40	°C/W
Human-body model (HBM)	ESD	4	KV

* Stresses beyond those listed under absolute maximum ratings may cause permanent damage to the device. These are stress ratings only, and functional operation of the device at these or any other conditions beyond those indicated under recommended operating conditions is not implied. Exposure to absolute-maximum-rated conditions for extended periods may affect device reliability.

8. Recommended operation conditions

Parameter	symbol	MIN	Typical	MAX	Unit
Input voltage	V_{IN}	4.65	5	5.5	V
Load current	I	0	3.1	4	A

* Beyond these operation conditions, the device's performance will not be guaranteed.

9. Electrical Characteristics

$T_A=25^\circ\text{C}$, $L=1\mu\text{H}$ unless otherwise noted.

Parameter	symbol	Test condition	MIN	TYP	MAX	Unit
Charger system						
Input voltage	V_{IN}		4.65	5	5.5	V
Input voltage OVP	$V_{VINOV P}$	VIN over-voltage threshold	5.51	5.6	5.8	V
	$V_{VBUSOV P}$	VBUS over-voltage threshold	5.60	5.75	5.9	V
Input voltage UVP	V_{INUVP}		4.3	4.4	4.65	V
CV charge voltage	$CV_{4.2V}$	VSET is floating	4.21	4.24	4.27	V
	$CV_{4.35V}$	VSET is connected to GND	4.36	4.38	4.42	V
	$CV_{4.4V}$	VSET is connected to VBAT	4.41	4.43	4.46	V
stop charge current	I_{stop}	VIN=5V	200	300	500	mA
Charge current	I_{VIN}	VIN=5V	1.7	2	2.3	A
	I_{chg_bat}	VBUS=5V	2.3	2.8	3.2	A

Trickle charge current	I_{TRKL}	VIN=5v, BAT=2.7v	50	150	300	mA
Trickle charge stop voltage	V_{TRKL}		2.9	3	3.1	V
Recharge threshold	V_{RCH}		4.08	4.1	4.13	V
Charger safety timer	T_{END}		20	24	27	Hour
Boost system						
Battery operation voltage	V_{BAT}		2.9		4.4	V
Battery low protection voltage	V_{BATLOW}	IOUT=2A	2.85	2.95	3.1	V
Battery operation current	I_{BAT}	VBAT=3.7V, VOUT=5.1V, fs=375KHz	2	5	20	mA
DC-DC output voltage	V_{OUT}	VBAT=3.7V @0A	5.0	5.12	5.25	V
		VBAT=3.7V @3.1A	4.75	5	5.25	V
Output voltage ripple	ΔV_{OUT}	VBAT=3.7V, VOUT=5.0V, fs=375KHz	50	100	150	mV
Boost output current	I_{vout}		0	3.1		A
Boost output shutdown current			3.15	3.8	5	A
Load over-current detect timer	T_{UVD}	Output voltage continuously lower than 4.4V	10	30	50	ms
Load short-circuit detect timer	T_{OCP}	Output current continuously larger than 5A	100	150	200	us
Control system						
Switching frequency	f_s	Boost switching frequency	300	375	450	KHz
		Charger switching frequency	450	500	550	KHz
PMOS on resistance	$r_{DS(on)}$		15	20	25	mΩ
NMOS on resistance			10	15	20	mΩ
PMOS between VIN and VOUT on resistance		VIN=5V	60	75	90	mΩ
Battery standby current	I_{STB}	VIN=0V, VBAT=3.7V	50	100	150	uA
LED lighting current	I_{light}		20	30	40	mA
LED indicator current	I_{L1}					
	I_{L2}		2	10	20	mA
	I_{L3}					
Load removal detect timer	T_{loadD}	Load current continuously lower than 45mA	25	32	44	s
Push-button wake-up timer	$T_{OnDebounce}$		50	60	300	ms
Push-button light-on timer	$T_{Keylight}$		1.2	2	3	s

Thermal shutdown	T_{OTP}	Rising temperature	110	140	150	°C
Thermal shutdown hysteresis	ΔT_{OTP}		30	40	50	°C

10. Function description

Boost converter

IP5310 integrates a 5V output step-up DCDC converter with 3.1A output capacity. It works at 375 KHz. When input voltage is 3.7V, its efficiency is 95% with the output of 5V/2.1A, 92.5% with the output of 5V/3.1A. Internal soft-start circuit prevents malfunction caused by starting inrush current. It integrate short-circuit, over-voltage, over-voltage protection, making the system stable and reliable.

IP5310's boost converter has a thermal regulation loop, which can adaptively regulate the output current to insure IC temperature below the set one.

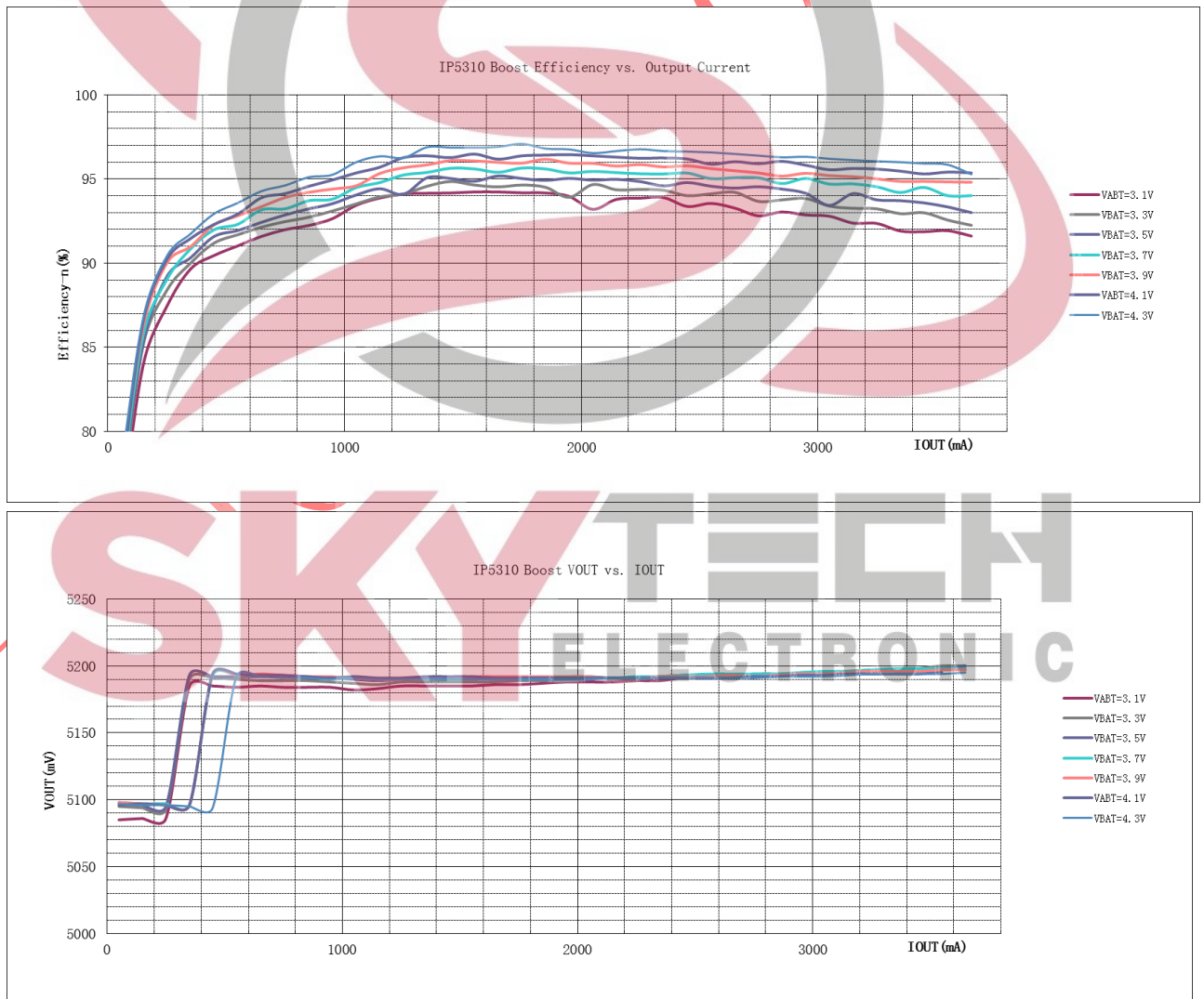

Fig 4 IP5310 Boost Efficiency and VOUT Vs. IOUT

Charger

IP5310 integrates a synchronous constant-current and constant-voltage switching Li battery charger. When battery is below 3.0V, the charger is in trickle mode, and charging current is 100mA. When battery is above 3V, the charger turns to constant-current mode, and constant-voltage mode is used if battery voltage reaches 4.2V. When charge is over, recharge will begin if battery is below 4.1V.

IP5310's switching charger has a 500KHz switching frequency, and its maximum charging current is 1.2A, charging efficiency is up to 97%, shortening 3/4 charging time in comparison with the normal chargers.

IP5310's charger can adapt the charging current to the adapter of various load capacity, which can keep adapters away from malfunction.

IP5310's charge current can up to 5V/3A, when use TYPE-C port; and when use MICRO-B port, the max charge current is 2A.

IP5310 Support BC1.2 protocol detection and compatible with PC USB port to charge.

State-transition diagram

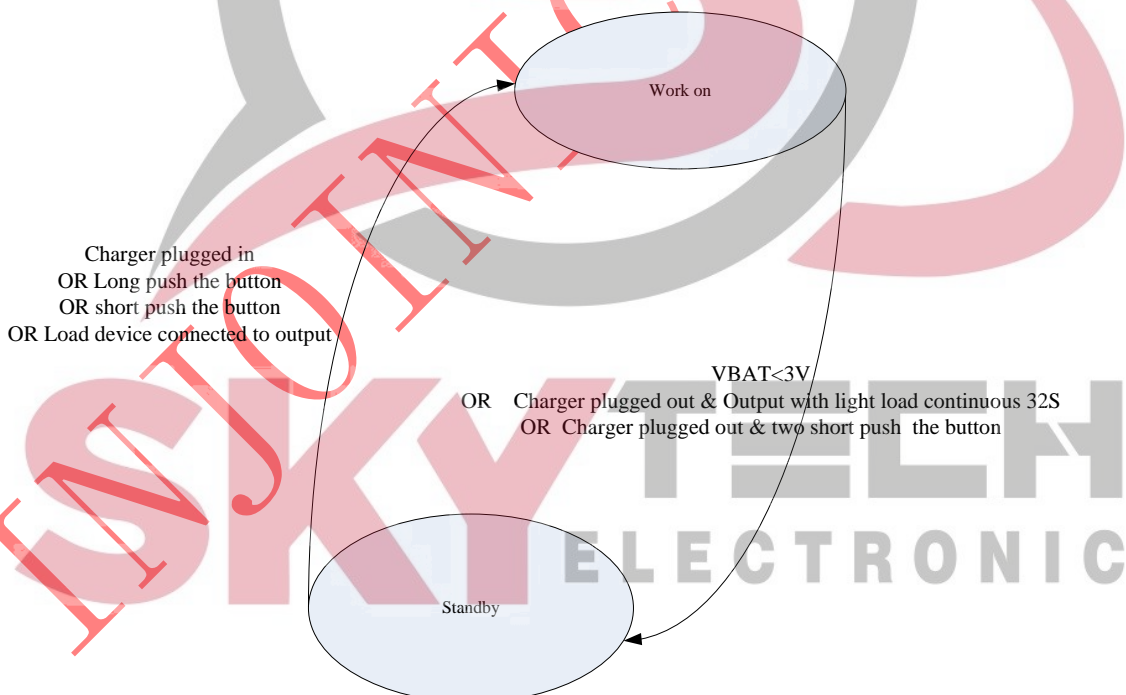

TYPE-C Interface

The built-in Type-C DRP protocol by IP5310 can supports single port input and output function. It support Try.SRC function, and prior to as source port when connect DRP device.

When IP5310 is Downstream-Facing Port (DFP), the CC pins advertises Default、 1.5A、 3A for Type-C power. As

Upstream-Facing Port (UFP), IP5310 can determine the advertised current from the DFP.

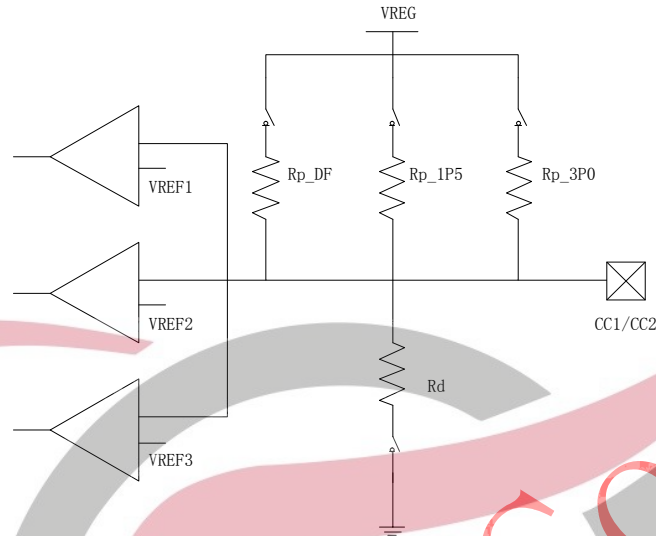

Pull-up/Pull-down Resistor

Resistor Type	Resistor Value
Rp_DF	33k
Rp_1P5	11k
Rp_3P0	4.2k
Rd	5.1K

CC Voltage Threshold on Source Side

Table 4-21 CC Voltages on Source Side - Default USB

	Minimum Voltage	Maximum Voltage	Threshold
Powered cable/adaptor (vRa)	0.00 V	0.15 V	0.20 V
Sink (vRd)	0.25 V	1.50 V	1.60 V
No connect (vOPEN)	1.65 V		

Table 4-22 CC Voltages on Source Side - 1.5 A @ 5 V

	Minimum Voltage	Maximum Voltage	Threshold
Powered cable/adaptor (vRa)	0.00 V	0.35 V	0.40 V
Sink (vRd)	0.45 V	1.50 V	1.60 V
No connect (vOPEN)	1.65 V		

Table 4-23 CC Voltages on Source Side - 3.0 A @ 5 V

	Minimum Voltage	Maximum Voltage	Threshold
Powered cable/adaptor (vRa)	0.00 V	0.75 V	0.80 V
Sink (vRd)	0.85 V	2.45 V	2.60 V
No connect (vOPEN)	2.75 V		

CC Voltage Threshold On Sink Side

Table 4-25 Voltage on Sink CC pins (Multiple Source Current Advertisements)

Detection	Min voltage	Max voltage	Threshold
vRa	-0.25 V	0.15 V	0.2 V
vRd-Connect	0.25 V	2.04 V	
vRd-USB	0.25 V	0.61 V	0.66 V
vRd-1.5	0.70 V	1.16 V	1.23 V
vRd-3.0	1.31 V	2.04 V	

Type-C Detect Timing

Figure 4-36 DRP Timing

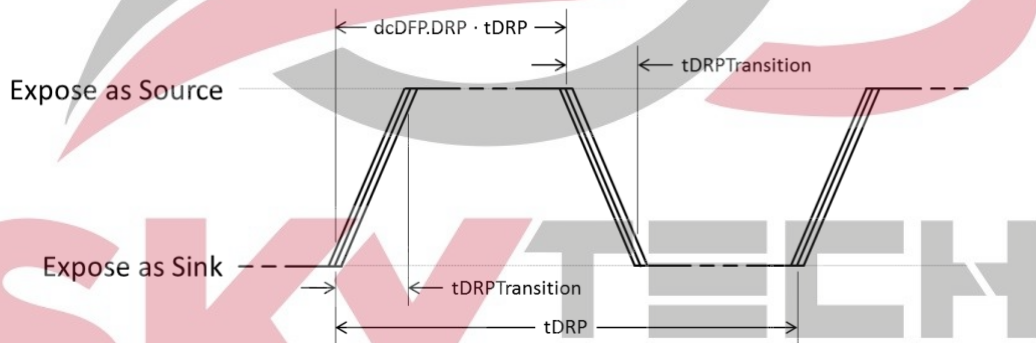
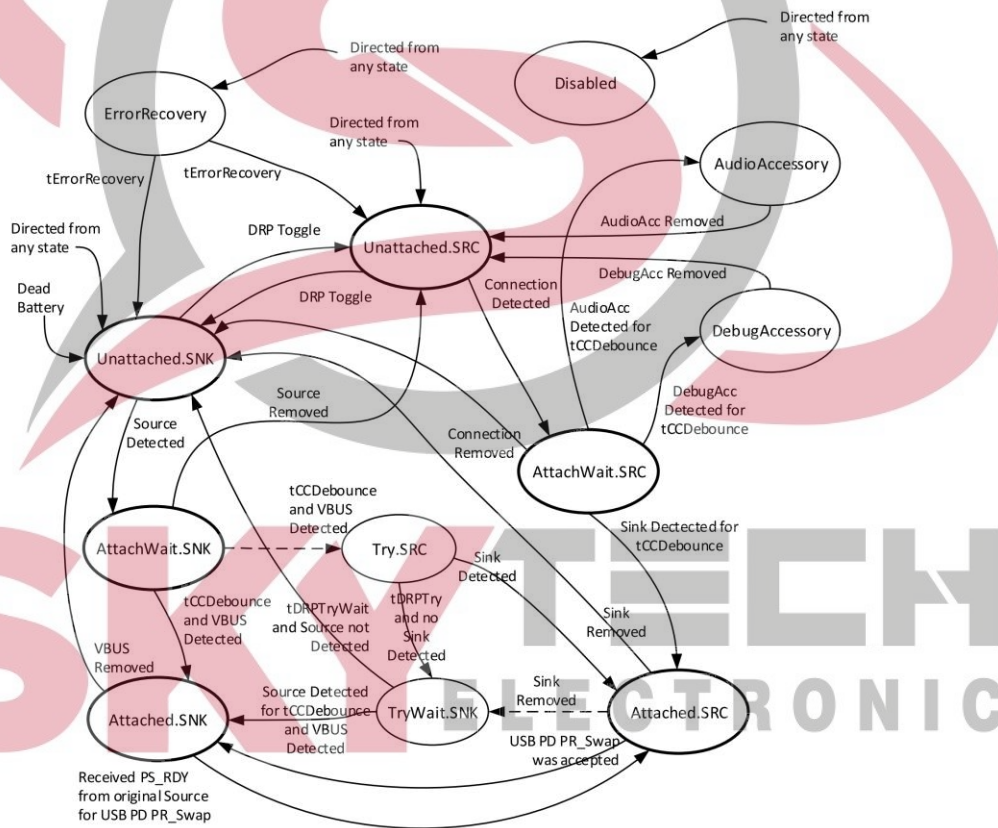

Table 4-19 DRP Timing Parameters

	Minimum	Maximum	Description
tDRP	50 ms	100 ms	The period a DRP shall complete a Source to Sink and back advertisement
dcSRC.DRP	30%	70%	The percent of time that a DRP shall advertise Source during tDRP
tDRPTransition	0 ms	1 ms	The time a DRP shall complete transitions between Source and Sink roles during role resolution
tDRPTry	75 ms	150 ms	Wait time associated with the Try.SRC state.
tDRPTryWait	400 ms	800 ms	Wait time associated with the TryWait.SNK state

Type-C State Machine

Figure 4-16 Connection State Diagram: DRP with Accessory and Try.SRC Support



Push Button

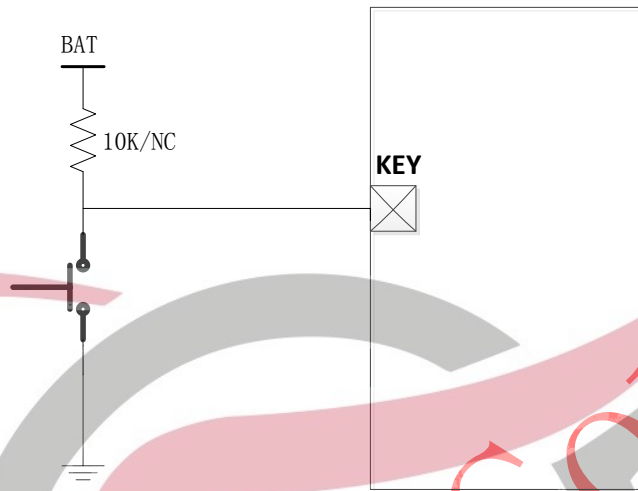

Fig 5 KEY button

Push button's connecting is shown in Fig 5. IP5310 can identify long push and short push.

When KEY PIN is not connected to BAT by 10K resistance:

- If button is pushed longer than 60ms but shorter than 2s, IP5310 will identify the action as short push. Short push will open SOC indicator LEDs and step-up converter
- If button is pushed longer than 2s, IP5310 will identify the action as long push. Long push will open or close flashlight LED.
- If button is pushed shorter than 60ms, IP5310 will ignore the action.
- If two short push is detected within 1s, IP5310 will close step-up converter, SOC indicator LED and flashlight LED.

When KEY PIN is connected to BAT by 10K resistance:

- If button is pushed longer than 60ms but shorter than 2s, IP5310 will identify the action as short push. Short push will open SOC indicator LEDs and step-up converter
- If button is pushed longer than 2s, IP5310 will identify the action as long push. Long push will open or close flashlight LED.
- If button is pushed shorter than 60ms, IP5310 will ignore the action.
- If two short push is detected within 1s, IP5310 will ignore the action.

Fuel gauge and State Of Charge (SOC) indication

IP5310 has an integrated fuel gauge, which can indicate the battery's state of charge accurately.

IP5310 can support 4/3/2/1 LEDs as the SOC indicator with very simple configuration. By the built-in identification algorithm, IP5310 can automatically identify how many LEDs are used as the SOC indicator.

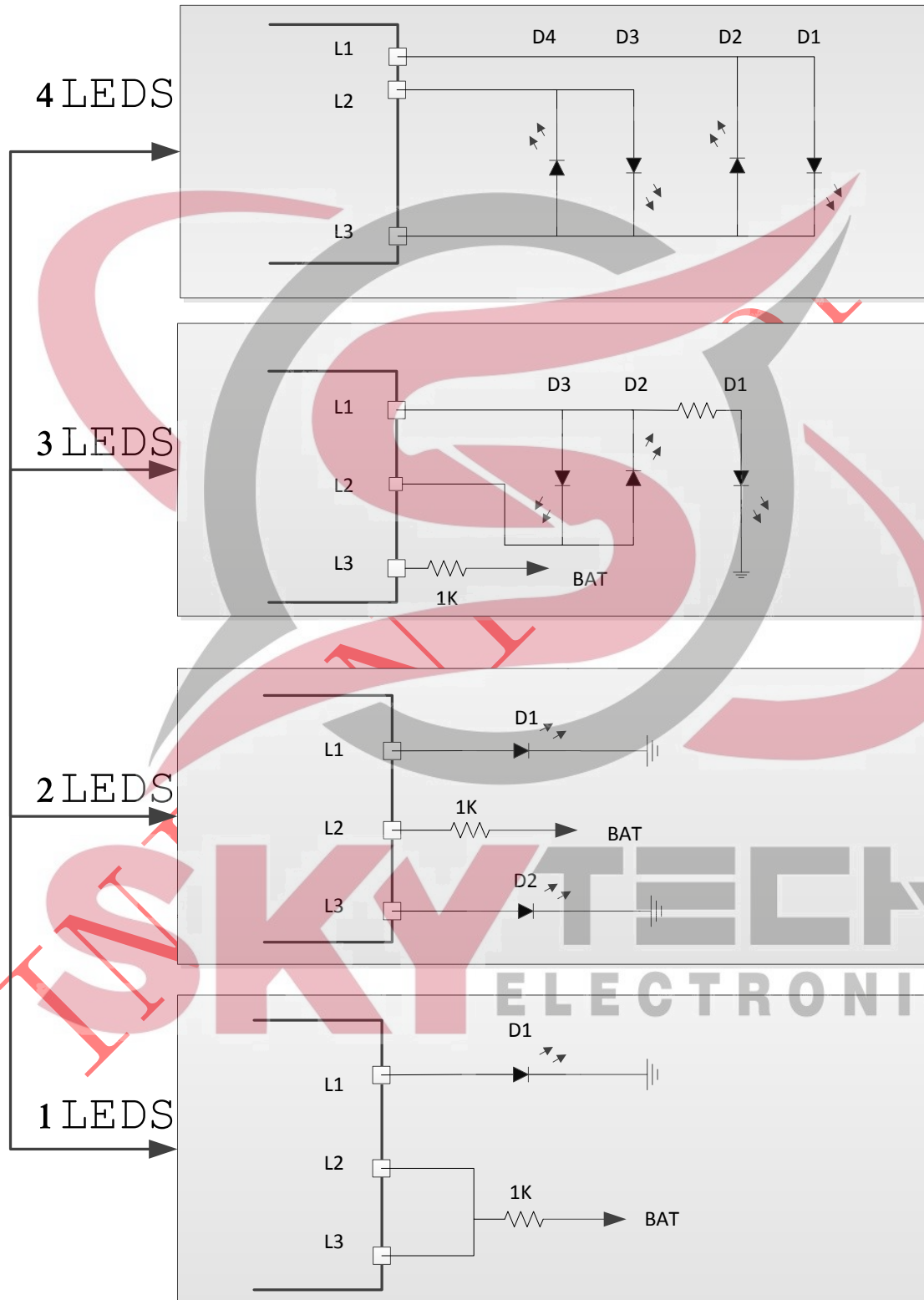

Fig 6 4/3/2/1 LED PIN configuration

Discharging mode, 4 LEDs as the indicator

SOC (%)	D1	D2	D3	D4
$C \geq 75\%$	ON	ON	ON	ON
$50\% \leq C < 75\%$	ON	ON	ON	OFF
$25\% \leq C < 50\%$	ON	ON	OFF	OFF
$3\% \leq C < 25\%$	ON	OFF	OFF	OFF
$0\% < C < 3\%$	1Hz blink	OFF	OFF	OFF

Charging mode, 4 LEDs as the indicator

SOC (%)	D1	D2	D3	D4
Full	ON	ON	ON	ON
$75\% \leq C$	ON	ON	ON	0.5Hz blink
$50\% \leq C < 75\%$	ON	ON	0.5Hz blink	OFF
$25\% \leq C < 50\%$	ON	0.5Hz blink	OFF	OFF
$C < 25\%$	0.5Hz blink	OFF	OFF	OFF

The displays of 3 LEDs are similar to that of 4 LEDs. The corresponding SOC of each LED is presented in the following table.

	D1	D2	D3	D4
3 LEDs	33%	66%	100%	NA
4 LEDs	25%	50%	75%	100%

■ 2 LED Display Mode

	Status	D1	D2
Charge	In charge	0.5Hz blink	OFF
	End of charge	ON	OFF
Discharge	Boost	OFF	ON
	Low Battery	OFF	1Hz blink

■ 1 LED Display Mode

	Status	D1
Charge	In charge	0.5Hz blink
	Full charge	ON
Discharge	Boost	ON
	Low Battery	1Hz blink

Battery impedance setting

IP5310 can set the battery impedance by RSET pin which make the SOC indicator LEDs display more evenly. The relationships between the resistance connected to RSET and battery impedance are shown in the following table.

RSET resistance (Kohm)	Battery impedance (mOhm)
10K	45
33K	67.5
68K	90
100K	30
NC	22.5

Automatic cellphone plug-in detect

IP5310 can automatically detect the cellphone's plug-in. When detecting the plug-in, IP5310 will wake up from standby mode and open the 5V step-up converter without push button action. IP5310 supports modules without push buttons.

Cellphone charging current smart detect

IP5310 integrates two DCP modules which can smartly detect the cellphone's charging current. It automatically provides the correct signals on DP and DM. It makes the cellphone's charging current to the maximum, accelerating the charging speed on cellphone.

IP5310 supports Apple, Samsung and BC1.2 interface's D+ D- specification:

- Supports D+ D- shorted USB DCP
- Supports D+ 2.0V D-2.7V Apple 1.0A DCP
- Supports D+ 2.7V D-2.0V Apple 2.0A DCP
- Supports D+ 2.7V D-2.7V Apple 2.4A DCP
- Supports D+ 1.2V D-1.2V Samsung 2.0A DCP

Battery voltage selection

IP5310 can support different batteries by changing the connecting of VSET PIN. When VSET is floating, 4.2V battery is set. When VSET is connected to GND, 4.35V battery is set. When VSET is connected to BAT, 4.4V battery is set.

Battery platform selection

IP5310 can set different battery curve by changing the connecting of VTHS PIN. The Relationship between OCV

(battery voltage detected by IP5310, after calculating the battery resistance compensation) and VTHS&VSET as follows:

VTHS	OCV threshold to change led	4.2V battery	4.35V and 4.4V battery
connect to BAT	4LED to 3LED	4.02V	4.02V
	3LED to 2LED	3.9V	3.84V
	2LED to 1LED	3.78V	3.78V
Float	4LED to 3LED	3.96V	4.02V
	3LED to 2LED	3.78V	3.84V
	2LED to 1LED	3.6V	3.66V
connect to GND	4LED to 3LED	3.96V	4.02V
	3LED to 2LED	3.72V	3.78V
	2LED to 1LED	3.6V	3.6V

NTC

IP5310 integrated NTC, and can detect battery pack temperature. IP5310's NTC PIN will output 20uA current, then detect the voltage of NTC PIN to determine the temperature of the battery.

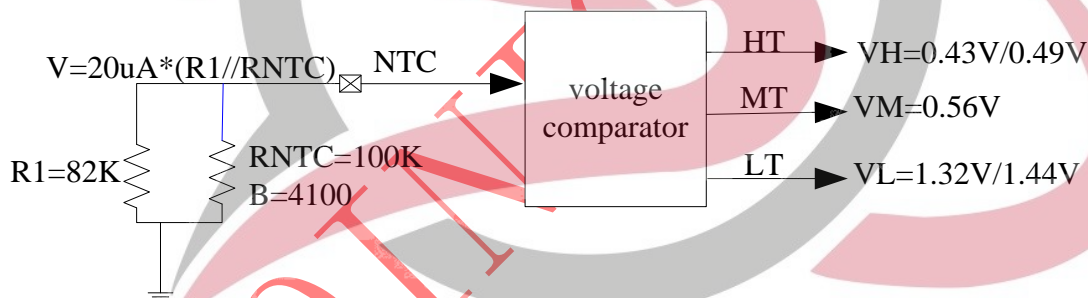

Fig7 Battery NTC threshold

Charge:

If NTC pin voltage > 1.32V, it indicate the battery temperature is below 0 ° C, charger is stopped.

If NTC pin voltage < 0.56V, it indicate the battery temperature is higher 45 ° C, half charging current is used.

If NTC pin voltage < 0.49V, it indicate the battery temperature is higher 50 ° C, charger is stopped.

Discharge:

If NTC pin voltage > 1.44V, it indicate the battery temperature is below -10 ° C, Output will be shutoff.

If NTC pin voltage < 0.43V, it indicate the battery temperature is higher 55 ° C, Output will be shutoff.

If NTC function is not needed, the NTC pin should connect a 51K resistor to GND. The NTC pin cannot float otherwise may lead to abnormal.

Flash Light

IP5310 has an integrated MOS FET. LIGHT PIN in IP5310 can drive lighting LED directly. Maximum driving current is 30mA. When button is pushed longer than 2s, lighting LED is opened or closed. If flash light is not needed, light should connect to GND, IP5310 will automatically close flash light.

I2C Interface

I2C connection mode

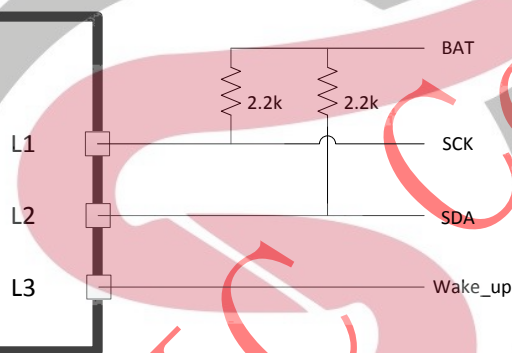

- The I2C speed support 400Kbps.
- Support 8 bit address width and 8bit data width.
- Transmit and receive MSB first.
- I2C address: write is 0xEA, and read is 0xEB.

Example: Write 8bit data 0x5A to register 0x05:

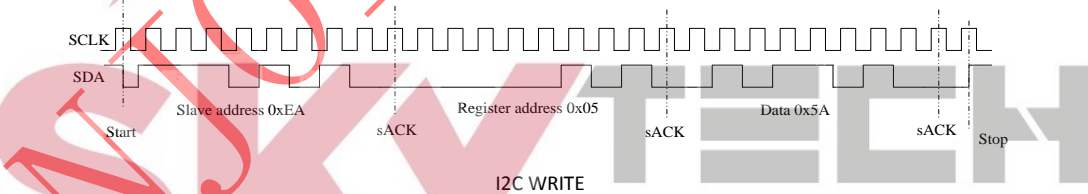

Example: Read 8bit data 0x5A from register 0x05:

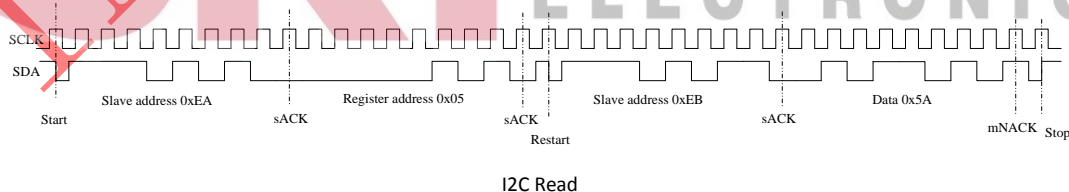

In I2C mode, IP5310's L3 PIN will be in low-level when IP5310 standby. L3 PIN will be in high-level when IP5310 work on. L3 can be used as a wake-up signal to MCU.

When use I2C, please apply for IP5310_I2C.

11. Typical application schematic

IP5310 only needs capacitors, resistors, and inductors to realize a full featured power bank solution.

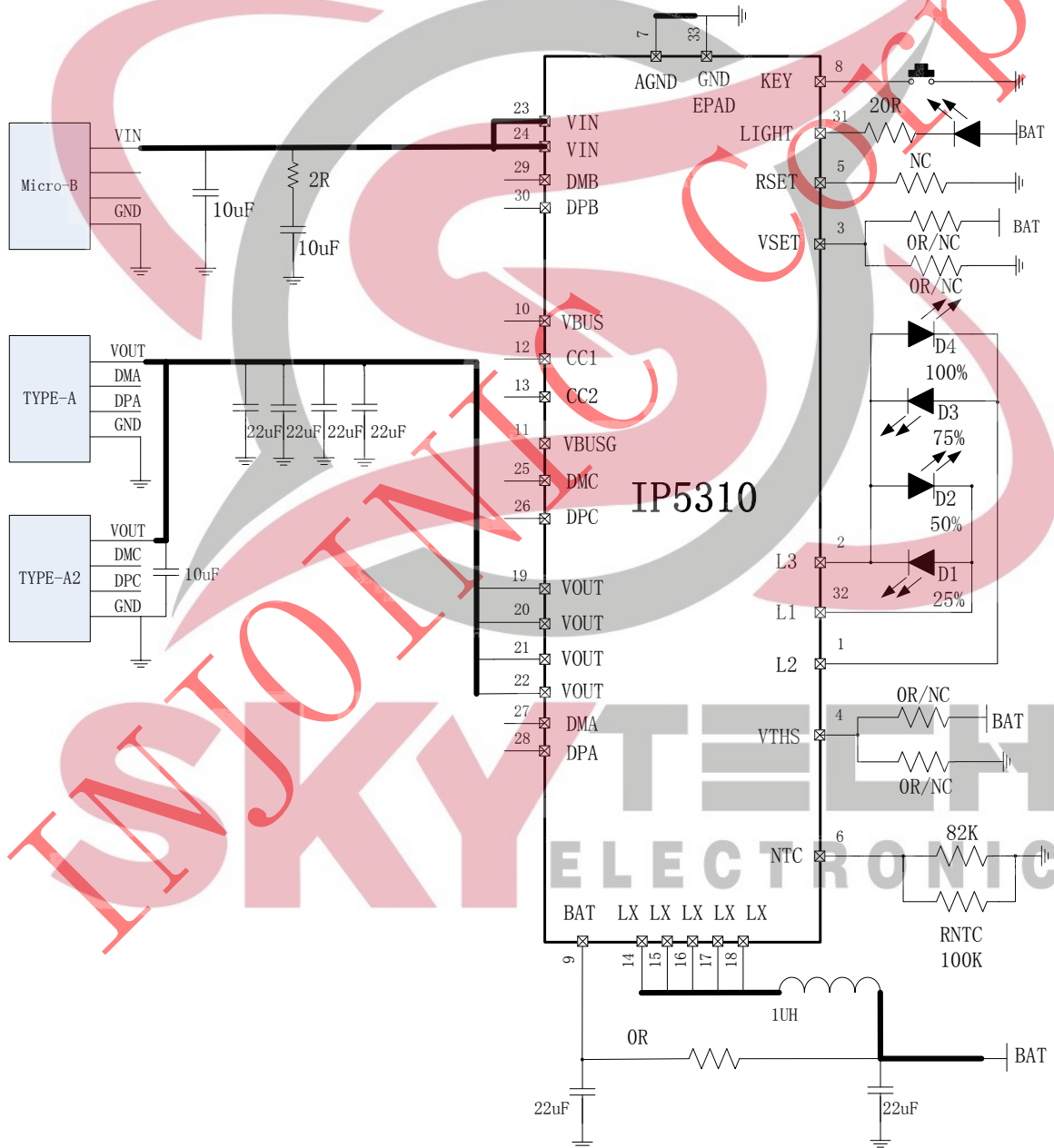

Fig 7 Typical Application Schematic with AAB (4 LEDs SOC indicator)

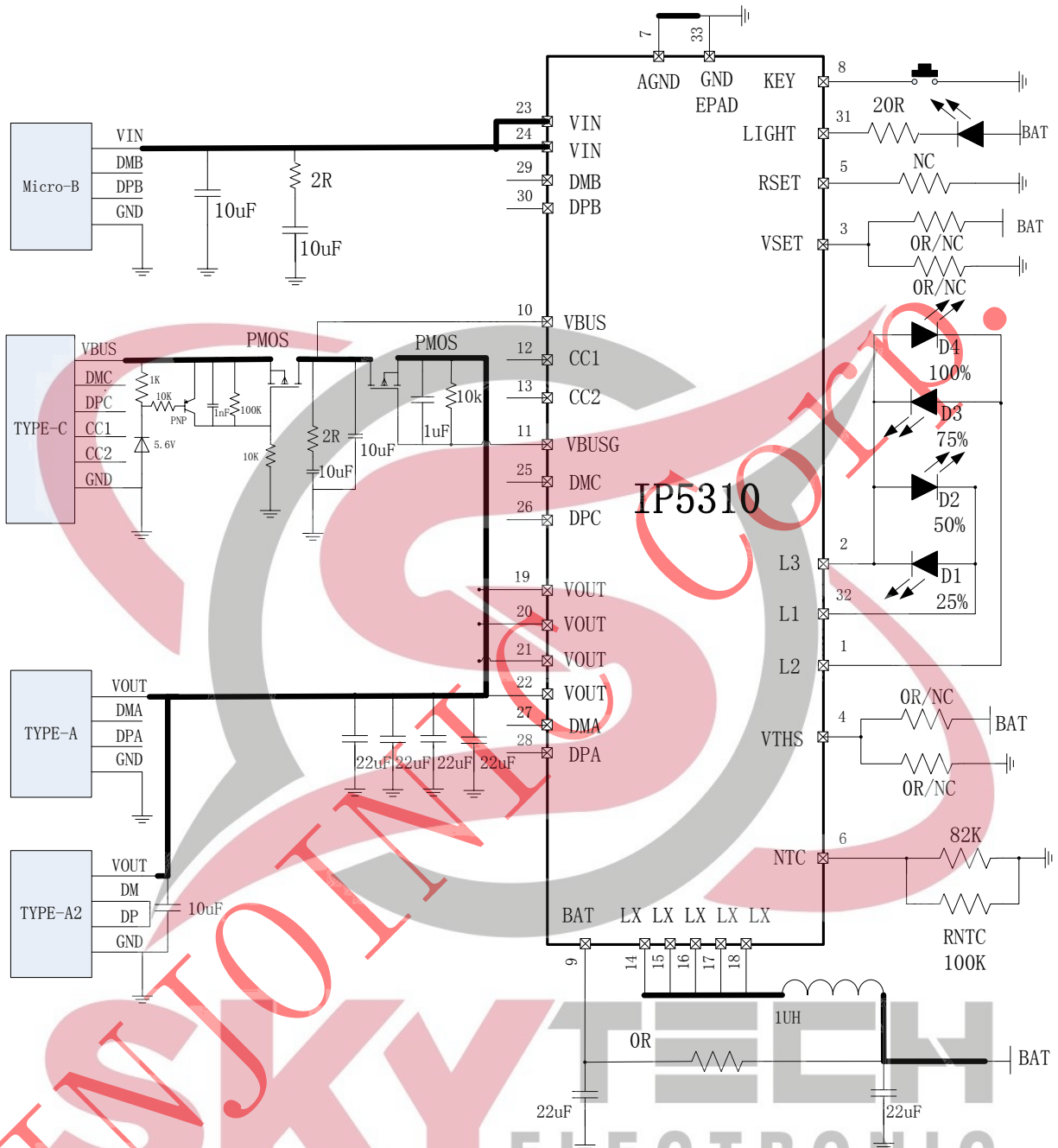

Fig 8 Typical Application Schematic with AABC (4 LEDs SOC indicator)

Recommended inductor

SPM70701R0

DARFON PIN	Inductance (uH)	Tolerance	DC Resistance (mΩ)		Heat Rating	Saturation	Measuring Condition
			Typ.	Max.	Current DC Amp.	Current DC Amps.	
SPM10101R0MECN	1.0	±.01	3.0	3.3	Idc(A)Max. 18	Isat(A)Max. 36	

12. Package information

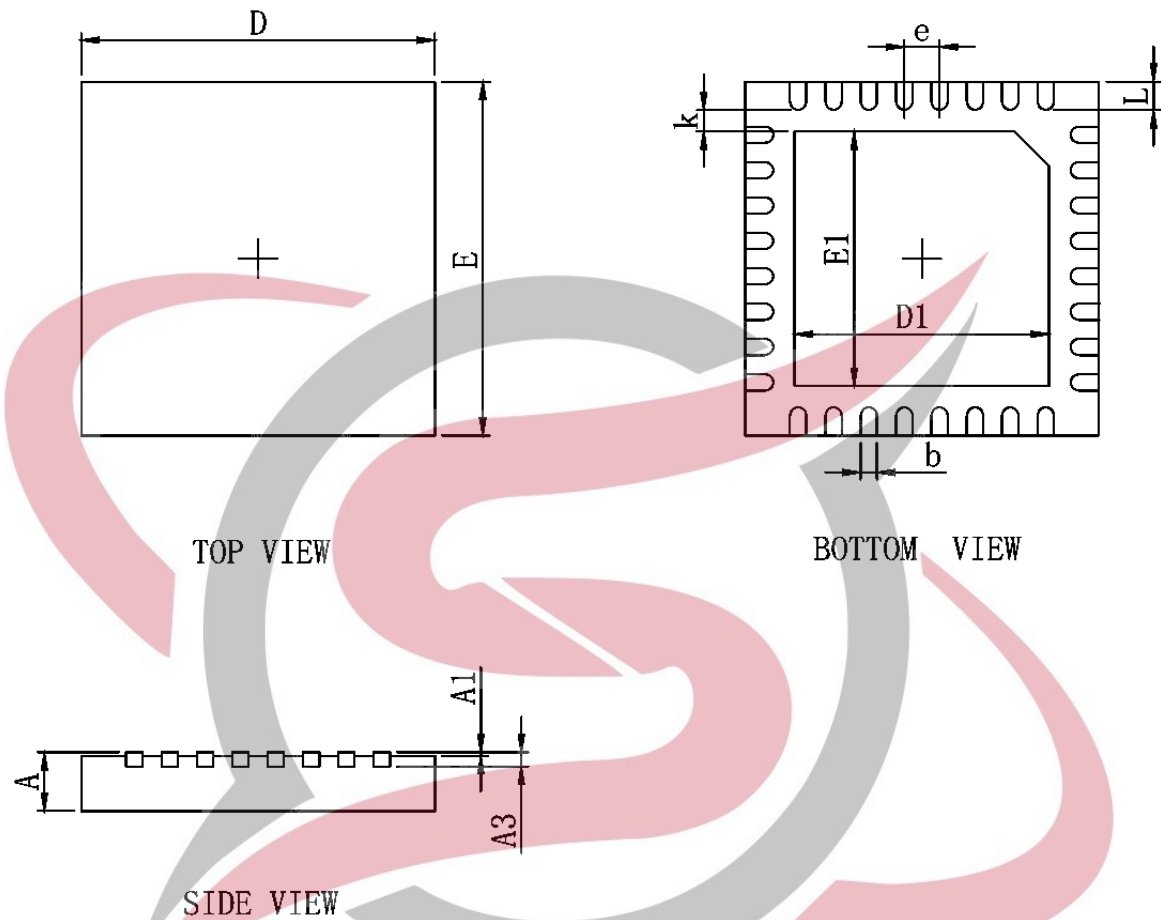

Symbol	Dimensions In Millimeters		Dimensions In Inches	
	Min.	Max.	Min.	Max.
A	0.700	0.800	0.028	0.031
A1	0.000	0.050	0.000	0.002
A3	0.203REF.		0.008REF.	
D	4.924	5.076	0.194	0.200
E	4.924	5.076	0.194	0.200
D1	3.300	3.500	0.130	0.138
E1	3.300	3.500	0.130	0.138
k	0.200MIN.		0.008MIN.	
b	0.200	0.300	0.008	0.012
e	0.500TYP.		0.020TYP.	
L	0.324	0.476	0.013	0.019

IMPORTANT NOTICE

INJOINIC TECHNOLOGY and its subsidiaries reserve the right to make corrections, enhancements, improvements and other changes to its semiconductor products and services. Buyers should obtain the latest relevant information before placing orders and should verify that such information is current and complete. All semiconductor products (also referred to herein as “components”) are sold subject to INJOINIC TECHNOLOGY's terms and conditions of sale supplied at the time of order acknowledgment.

INJOINIC TECHNOLOGY assumes no liability for applications assistance or the design of Buyers' products. Buyers are responsible for their products and applications using INJOINIC TECHNOLOGY's components. To minimize the risks associated with Buyers' products and applications, Buyers should provide adequate design and operating safeguards.

Buyer acknowledges and agrees that it is solely responsible for compliance with all legal, regulatory and safety-related requirements concerning its products, and any use of INJOINIC TECHNOLOGY's components in its applications, notwithstanding any applications-related information or support that may be provided by INJOINIC TECHNOLOGY. Buyer represents and agrees that it has all the necessary expertise to create and implement safeguards which anticipate dangerous consequences of failures, monitor failures and their consequences lessen the likelihood of failures that might cause harm and take appropriate remedial actions. Buyer will fully indemnify INJOINIC TECHNOLOGY and its representatives against any damages arising out of the use of any INJOINIC TECHNOLOGY's components in safety-critical applications.

Reproduction of significant portions of INJOINIC TECHNOLOGY's information in INJOINIC TECHNOLOGY's data books or data sheets is permissible only if reproduction is without alteration and is accompanied by all associated warranties, conditions, limitations, and notices. INJOINIC TECHNOLOGY is not responsible or liable for such altered documentation. Information of third parties may be subject to additional restrictions.

INJOINIC TECHNOLOGY will update this document from time to time. The actual parameters of the product may vary due to different models or other items. This document voids all express and any implied warranties.

Resale of INJOINIC TECHNOLOGY's components or services with statements different from or beyond the parameters stated by INJOINIC TECHNOLOGY for that component or service voids all express and any implied warranties for the associated INJOINIC TECHNOLOGY's component or service and is an unfair and deceptive business practice. INJOINIC TECHNOLOGY is not responsible or liable for any such statements.